



H&O DIE SUPPLY, INC. 1-800-222-5441 sales@hodie.com

VIBRO/DYNAMICS®

technologically advanced machinery mounting systems



Machine Mounts for Precision Industrial Machinery

MICRO/LEVEL® ISOLATORS
Series 2, 6 and 8



*Your best way to install and level machines
for effective control of vibration and noise*

TYPICAL APPLICATIONS



Metalworking Presses

Mechanical and Hydraulic
Turret Punch
Gap Frame
Brakes
Shears

Precision Machine Tools

Broaching Machines
Cold Headers
Drills
Gear Hobbers
Jig Grinders
Lathes
Machining Centers
Milling Machines
Precision Grinders
Saws
Transfer Lines
Upsetters
Wire EDM

Die Casting & Plastic Molding

Die Cast Machines
Injection & Blow Molders

Metal Container

Bodymakers and Wall-Ironers
Necker Flangers
Decorators and Fillers

Measuring Equipment

Coordinate Measuring Machines
Optical Comparators
Surface Plates

Others

Pumps
Textile Machinery
Turbine Generators
Transformers
Woodworking Equipment

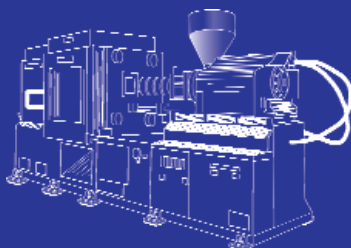

Faster, Easier Installation

Micro/Level Isolators eliminate the need for anchor bolts, shims, and grout. In most cases, no special foundations are required, getting you into production faster with minimum installation costs.

Vibration Control

Actual field tests showed that transmitted vibration can be reduced up to 98% with Micro/Level Isolators, improving machine performance, product quality, and protecting sensitive equipment and neighbors.

Precision Leveling and Alignment

The Micro/Level Isolator design makes precision leveling adjustments fast and easy. The isolator's leveling screw provides far greater leveling accuracy than shims or grout. Machinery relocations are just as fast, and if your floor or foundation should settle, releveling adjustments can be made with a simple turn of the wrench.

Proper Machine Support - Fine/Tuning

Precision leveling is critical to proper machine support. A machine can be level, yet not properly supported. Fine/Tuning is a process of making small, precise adjustments using the isolator's leveling screw to provide precise machine support. Fine/Tuning eliminates machine bed twist caused by improper support. Benefits include improved part quality, repeatability, and increased machine and tooling life.

Noise Reduction

A reduction in vibration results in a decrease in structural-borne noise. Noise reductions as high as 6.5 dB have been achieved using Micro/Level Isolators. Improved working conditions and reduced neighbor complaints are obvious benefits.

Meets OSHA Anchoring Requirements

The custom-engineered elastomers in Micro/Level Isolators offer an excellent coefficient of friction to eliminate machine walking to meet the OSHA anchoring requirements.





"L" & "K" Types

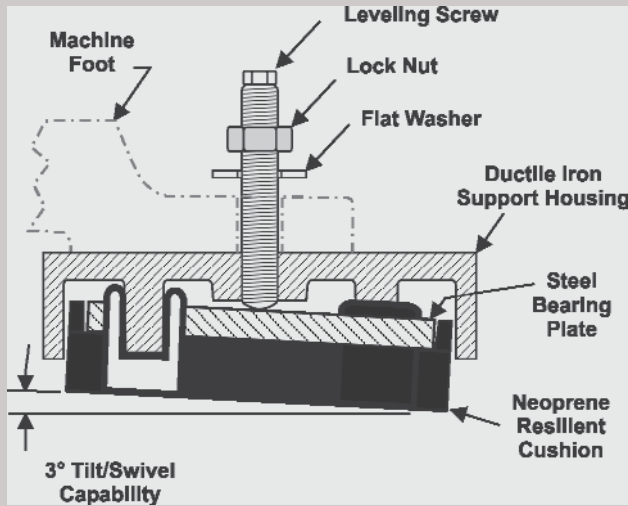

Series 2L, 6L and 8L isolators are ideal for machine tool and punch press applications. Series 6K and 8K isolators are the best choice for machines generating high inertia force like high-speed presses, die cast machines, cold headers and plastic injection molders.

(Use Isolator Selection Table 1 for these isolators).

"M" Type

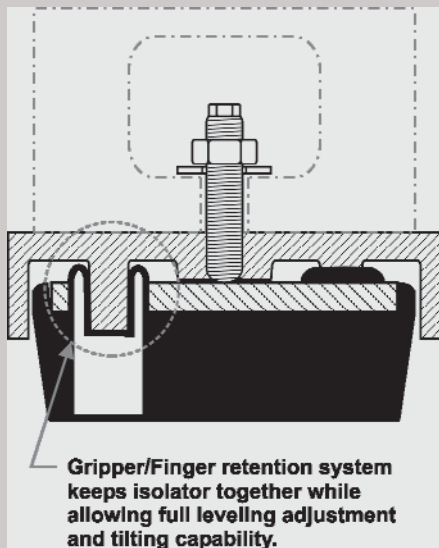

Series 6M and 8M are very soft isolators with thick elastomers designed to protect precision equipment in high vibration environments. These isolators are designed for Non-Impact machines generating very low inertia. Ideal for coordinate measuring machines, surface plates, jig grinders and EDMs.

(Use Isolator Selection Table 2 for these isolators).

"i" Type

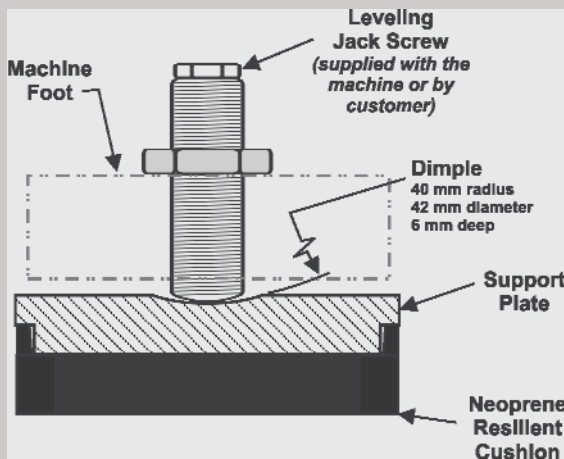

Series 6iK, 6iL, 6iM, 8iK, 8iL and 8iM have all of the above isolator characteristics, but are designed specifically for machines with leveling jack screws in their base. These isolators simply slide under the jack screws, replacing the existing leveling pads.

(Use Isolator Selection Table 1 or 2 depending on L, K or M Type).

ISOLATOR SPECIFICATIONS						
Isolator Model	Leveling Screw Diameter & Pitch	Maximum Load (lbs.)		Isolator Dimensions (inches)		
		Presses	Machine Tools	Diameter	Minimum Height	Leveling Adjustment
2L4	0.25-20 UNC	25	25	2.5	1	0.25
2L10		50	50			
2L20		100	100			
6L17	0.375-16 UNC	850	1250	5.63	1.75	0.5
	0.5-13 UNC					
	0.625-11 UNC					
6L40	0.375-16 UNC	850	1275	5.63	1.75	0.5
	0.5-13 UNC	2200	2300			
	0.625-11 UNC	2300	2300			
6K75	0.375-16 UNC	850	1275	5.63	1.88	0.5
	0.5-13 UNC	2200	3300			
	0.625-11 UNC	3500	3800			
6iL	Leveling Screws are not supplied.			5.0	1.5	
6iK	40mm radius - 6 mm deep dimple provided.					
8L150	0.625-11 UNC	3500	5250	8.13	2.5	0.75
	0.75-10 UNC	5300	7200			
	1-14 UNS	7200	7200			
8L220	0.625-11 UNC	3500	5250	8.13	2.5	0.75
	0.75-10 UNC	5300	7950			
	1-14 UNS	9300	9300			
8K80	0.625-11 UNC	3500	5250	8.13	2.5	0.75
	0.75-10 UNC	5300	7950			
	1-14 UNS	11,000	11,000			
8iL	Leveling Screws are not supplied.			7.5	2.0	
8iK	40 mm radius - 6 mm deep dimple provided.					
6M7	0.375-16 UNC	1000	5.63	2.5	0.5	
	0.5-13 UNC					
	0.625-11 UNC					
6M10	0.375-16 UNC	1200	5.63	2.5	0.5	
	0.5-13 UNC					
	0.625-11 UNC					
6M15	0.375-16 UNC	1275	5.63	2.5	0.5	
	0.5-13 UNC					
	0.625-11 UNC					
6M22	0.375-16 UNC	1275	5.63	2.5	0.5	
	0.5-13 UNC					
	0.625-11 UNC					
6iM	Leveling Screws are not supplied. 40 mm radius - 6 mm deep dimple provided.			5.0	2.18	
8M32	0.625-11 UNC	3800	8.13	3.13	0.75	
	0.75-10 UNC					
	1-14 UNS					
8M55	0.625-11 UNC	4900	8.13	3.13	0.75	
	0.75-10 UNC					
	1-14 UNS					
8M85	0.625-11 UNC	5250	8.13	3.13	0.75	
	0.75-10 UNC	6300				
	1-14 UNS	6300				
8iM	Leveling Screws are not supplied. 40 mm radius - 6 mm deep dimple provided.			7.5	2.37	

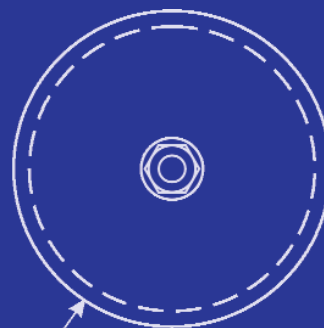

DIAMETER
(See Table)

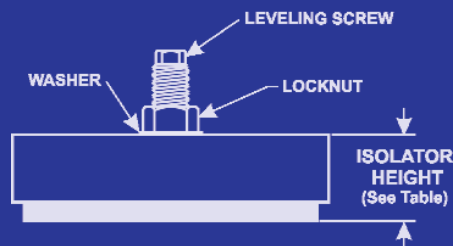

ISOLATOR MODEL NUMBER KEY

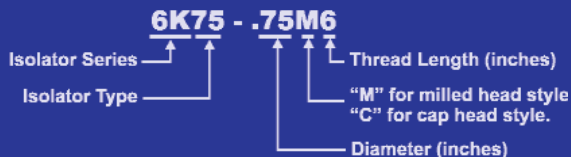

Leveling Screw Model	Foot Thickness Up To:		
	(inch)		
	Isolator Series		
	2	6	8
.25C1	0.38		
.375C4		2.4	
.375C6		4.4	
.5M3		1.3	
.5M5		3.3	
.5M8		6.3	
.625M4		2.2	1.5
.625M5		3.2	2.5
.625M6		4.2	3.5
.625M8		6.2	6.5
.75M4			1.5
.75M6			3.5
.75M8			5.5
1M4			1.4
1M5			2.4
1M6			3.4
1M8			5.4

Note: The machine mounting hole is used as a clearance hole for the isolator leveling screw.

See Isolator Selection and Application Guide for detailed information on selecting the best isolators for your machine.



VIBRO/DYNAMICS Corporation

2443 Braga Drive, Broadview, IL 60155-3941

Telephone 708.345.2050 Fax 708.345.2225

Toll-Free 800.842.7668 in the U.S.A.

website - www.vibrodynamics.com

email - vibro@vibrodynamics.com